



DG0640

600 Series

Galvanized Steel Slotted

PROJECT ID/
CONTRACT NO: _____

LOCATION: _____

ENGINEERING SPECIFICATION:

POLYCAST® DG0640 Grate is an economical alternative, the galvanized grate is appropriate for many general use conditions. Grating locking device Part No. DA0642 (not shown) should be used and maintained secure. The grate has 20% (41in²) of open area. The grate is made of hot dipped galvanized 14 gauge ASTM A36 Steel and weighs approximately 8lbs [3.63kg]. The grate is available in both 24" [610mm] and 48" [1219mm] lengths.

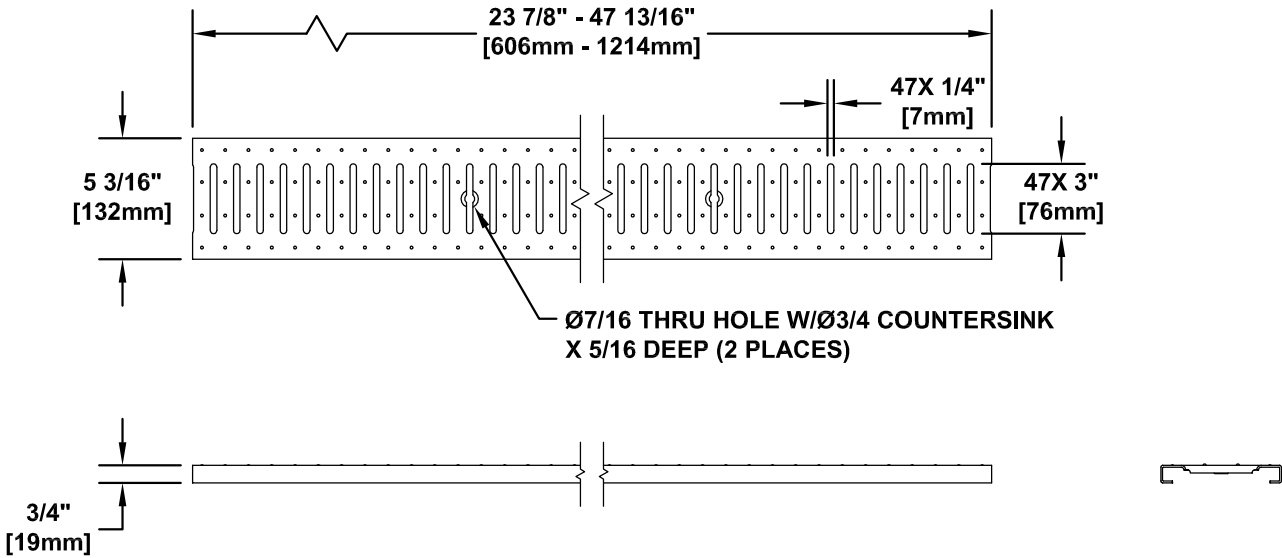
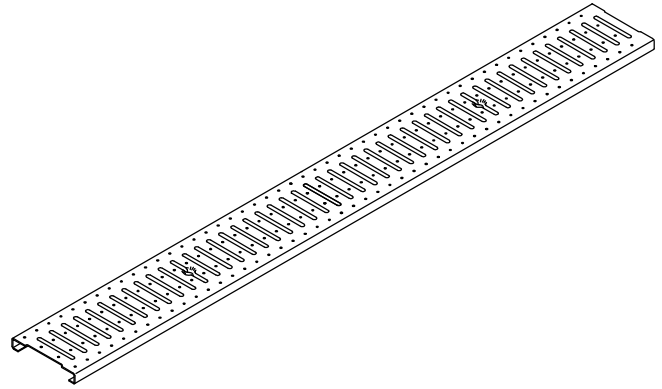

DIN APPLICATION LOAD CLASS A:
Residential, pedestrian and cyclist traffic
Designed for a distributed pressure of 3,372 lbs (15 kN).

Meets the following Standards & Specifications:

- DIN 19580 / DIN EN 1433 Drainage Channels for Vehicular and Pedestrian Areas
- Australian Standard AS 3996-2006 Clause 3.3.6



www.polycastdrain.com
Toll Free Number:
1-800-346-3062